



**CO<sub>2</sub> POWERED ENERGY MAX I.3J**  
 Muzzle Velocity 100m/s (328FPS)

# HI-CAPA CHALLENGER

Please read the [ Instruction Manual ] carefully and make full understanding of the details noted in the contents before use.

⚠ WARNING ⚠

- To avoid damaging the product, please release the gas from the magazines or cartridges while not operating.
- Sales and usage are restricted to 18-year-old people or older. Those below 18 years old are not allowed neither to purchase nor to operate alone.
- Never aim or shoot at people or animals. Please beware of childrens' mis-handling.
- Please read and fully understand all details listed in this instruction manual before using this air gun. You can download it from [www.icsbb.com](http://www.icsbb.com) if you lose this instruction manual.

6mm BB



## 1 PART DESCRIPTION

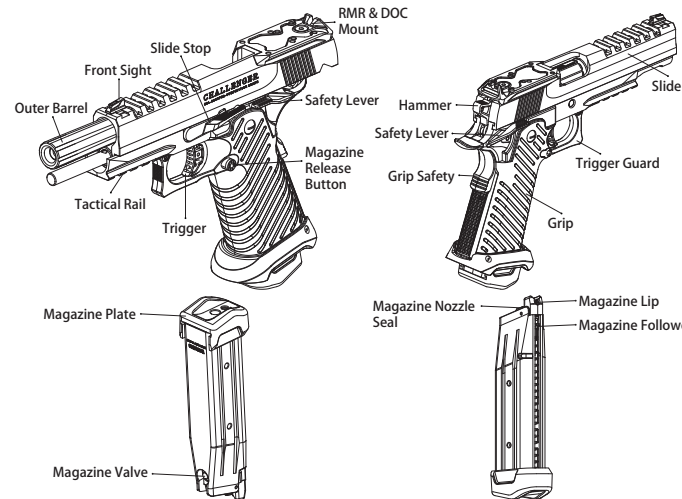

WARNING-ATTENTION



This model is featured with Gas-Blow-Back function. The slide will be pushed backward by the gas pressure strongly and rapidly while firing. To prevent injury, please keep your face and finger away from the slide.

● The pistol could be damaged when using at temperature of 30° C (86° F) or above.

## 2 SAFETY DEVICE

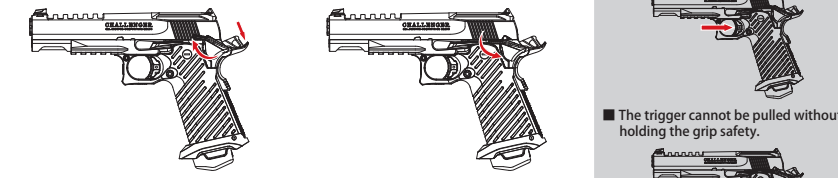

- Safety ON  
Engage the safety by cocking down the hammer then pressing up on the safety lever.  
※ The trigger and slide can not be pulled when the safety is engaged.  
※ Please press up the safety lever only when the hammer is cocked, or damage might be caused.
- Safety OFF  
Disengage the safety when you are going to fire.
- The trigger cannot be pulled without holding the grip safety.
- The trigger can be pulled when holding the grip safety firmly.

## 3 LOADING MAGAZINE



WARNING-ATTENTION

- To prevent misfiring, keep your finger off the trigger and out of the trigger guard while loading the magazine.
- For safety reason, please remove the magazine while not operating.

- Load the magazine until it clicks into the locking position.  
※ Do not insert the magazine by force.
- Release the magazine by pressing the magazine catch button.  
※ Hold the magazine when releasing it from the pistol grip to prevent it from dropping.

## 4 CO2 CARTRIDGE INSTALLATION

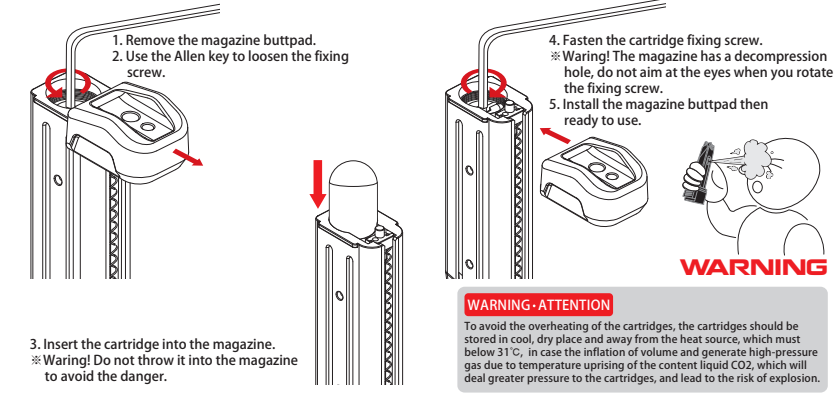

WARNING-ATTENTION

To avoid the overheating of the cartridges, the cartridges should be stored in cool, dry place and away from the heat source, which must be below 31° C, in case the inflation of volume and generate high-pressure gas due to temperature uprising of the content liquid CO<sub>2</sub>, which will deal greater pressure to the cartridges, and lead to the risk of explosion.

## 5 LOADING BBs

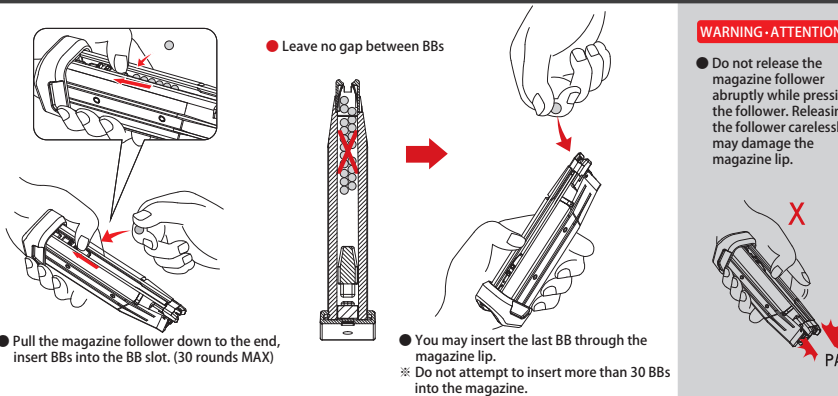

WARNING-ATTENTION

- Do not release the magazine follower abruptly while pressing the follower. Releasing the follower carelessly may damage the magazine lip.

- Pull the magazine follower down to the end, insert BBs into the BB slot. (30 rounds MAX)
- You may insert the last BB through the magazine lip.  
※ Do not attempt to insert more than 30 BBs into the magazine.

## 6 Trigger Pull Adjustment

Please use a 2mm Allen wrench to adjust the trigger pull hex screw.  
 ※ Please adjust according to personal habit.  
 △ The trigger could be locked by fastening the hex screw to the end, please release the screw properly.

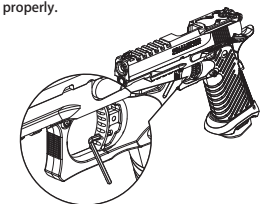

## 7 LOADING

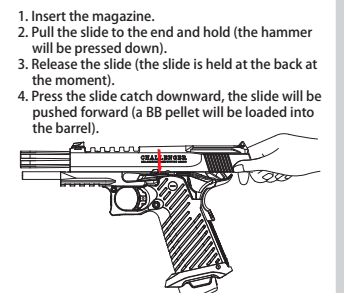

WARNING-ATTENTION

- Keep your face and fingers away from the slide while the slide is operating.
- When the magazine is detached, the slide stop will not lock the slide spontaneously after your releasing the slide.
- When the pistol is loaded, loading repeatedly will make the BBs load into the barrel repeatedly, which will lead to malfunction while firing and cause danger.
- When the hammer is pressed down, pulling the trigger will fire the bb. Please take extra notice.

## 8 SHOOTING

1. Switch the safety to FIRE.
2. Load the pistol according to step 7.
3. Pull the trigger to fire (a BB pellet will be fired and the slide will be pushed backward).

● The slide will be blown back and forth when firing.

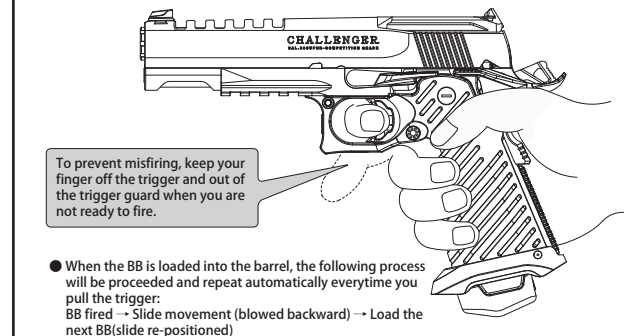

To prevent misfiring, keep your finger off the trigger and out of the trigger guard when you are not ready to fire.

- When the BB is loaded into the barrel, the following process will be proceeded and repeat automatically everytime you pull the trigger:  
BB fired → Slide movement (blowed backward) → Load the next BB (slide re-positioned)

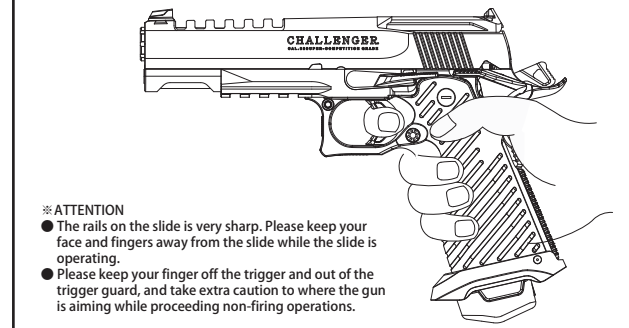

- ※ ATTENTION
- The rails on the slide is very sharp. Please keep your face and fingers away from the slide while the slide is operating.
  - Please keep your finger off the trigger and out of the trigger guard, and take extra caution to where the gun is aiming while proceeding non-firing operations.

WARNING-ATTENTION

- Power Depression  
When the temperature inside the magazine is too low, the gas power will be depressed.
- △ The movement of the slide will be delayed.
- △ The slide catch will not bounced.
- △ The shooting range will not be far.

- Shooting posture  
△ Please do not operate the pistol up side down for optimum performance.

## 9 STORAGE

- ① Press the magazine catch button to release the magazine.
- ② Make sure the inner barrel is clear. If not, pull the slide backward, and turn the pistol up side down to remove (push the BB pellet out from the barrel by the clearing rod is also recommended).
- ③ Press the slide catch lever to release the slide.
- ④ Pull the trigger and fire several times towards safety directions, and make sure no BBs are left inside the barrel.

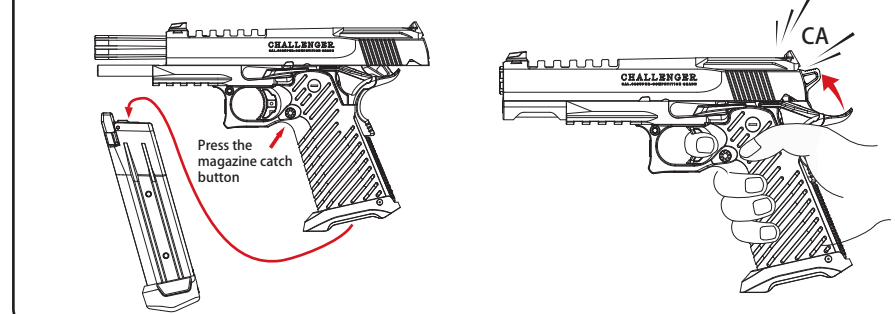



## 10 DISASSEMBLY (Do it when necessary)

Only disassemble your airsoft replica when adjusting the H-UP and proceeding to maintenance.

① Press the Magazine Release Button to unload the magazine.

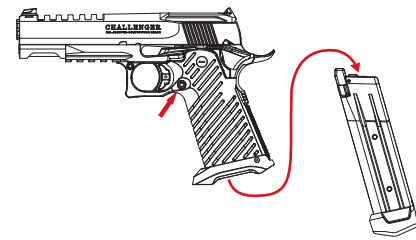

② Pull back the slide and press the slide stop upward to lock it.  
③ Insert the dedicated tool into the hole on the recoil spring guide as shown.

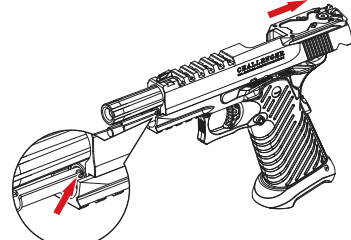

④ Push the Slide backward and align the notch corresponds to the slide stop as shown.

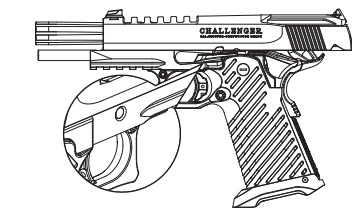

⑤ Press the slide stop button on the right to remove it.  
⑥ Push the slide forward to detach it. Meanwhile, The recoil spring guide set is contained.  
⑦ The recoil spring guide set can be easily removed by slightly pushing it forward and taking it out.  
⑧ Push the outer barrel set forward to remove. You may disassemble the recoil spring guide by detaching the dedicated tool if necessary.

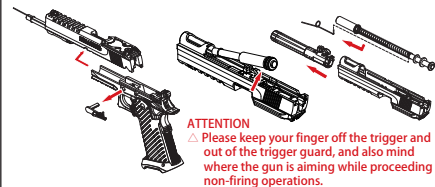

**ATTENTION**  
△ Please keep your finger off the trigger and out of the trigger guard, and also mind where the gun is aiming while proceeding non-firing operations.  
△ Watch out for the rod may bounce out of off the recoil spring guide set.

## 11 H-UP ADJUSTMENT

① Please disassemble and remove the slide as step 10 instructed.  
② Slightly rotate the screw to adjust the H-UP.

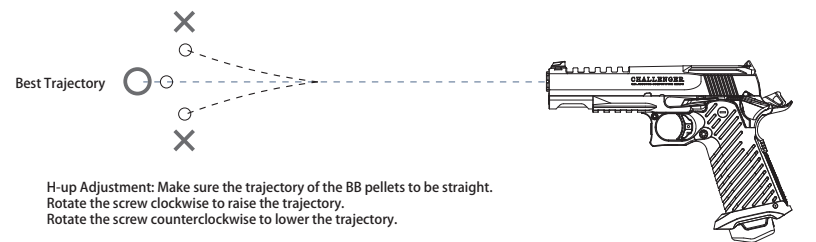
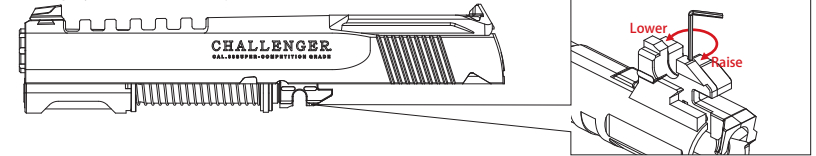

## 12 ASSEMBLY

※ Please check the following status before assembly:  
△ The hammer must be down pressed.

① Insert the dedicated tool into the hole on the rod and reverse Step 10, to assemble the recoil spring guide set.  
② Assemble the outer barrel set by pushing it back into the slide.  
③ Assemble the recoil spring guide set to the slide.

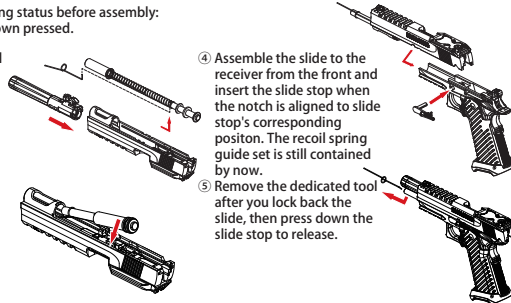

④ Assemble the slide to the receiver from the front and insert the slide stop when the notch is aligned to slide stop's corresponding position. The recoil spring guide set is still contained by now.  
⑤ Remove the dedicated tool after you lock back the slide, then press down the slide stop to release.

**WARNING-ATTENTION**  
● ICS will not be responsible for any part assembling errors, missing parts, and issues such as malfunctions, accidents, injuries, all the maintaining expenses will be borne by the customers.

## 13 BASIC TROUBLESHOOTING GUIDE

SYMPTOMS	POSSIBLE CAUSE	SOLUTIONS
No response	The safety is ON. (No firing)	Switch the safety to "OFF". (refer to step 2)
	Insufficient gas in the cartridge	Replace a new cartridge after confirming the cartridge is empty (refer to step 7, item 4 and step 4)
CO2 comes out from the barrel	Temperature is too low. (during the winter)	Reheat the cartridge to room temperature.
	Cartridge over-pressured	It will return normal after firing several times.
BBs fly up	H-UP is over adjusted.	Adjust the H-UP screw clockwise. (refer to step 9)
Shooting range is too short	H-UP is not enough.	Adjust the H-UP screw counter-clockwise. (refer to step 9)
	Foreign matters or oil in the inner barrel.	Clean the inner barrel and H-UP bucking.
BBs roll out of barrel	Cartridge over-pressured.	It will return normal after firing several times.
	H-UP is not enough.	Adjust the H-UP screw counter-clockwise. (refer to step 9)
Jammed	H-UP is over adjusted.	Adjust the H-UP screw clockwise. (refer to step 9)
	Bad BBs, oversize BBs	0.2g to 0.25g 6mm caliber BBs are recommended for optimum performance.
Trigger cannot be pulled.	Foreign matters or oil in the inner barrel.	Clean the inner barrel.
	BBs or foreign matters jam inside the case.	Take out the BBs or foreign matters.
CO2 leaking from perforated seat	Bad installation of the cartridge	Replace a new cartridge after confirming the cartridge is empty.(refer to step 7, item 4 and step 4)
	Not enough silicon oil for perforated seat .	Grease the perforated seat.
Magazine lip cannot hold the BBs.	Magazine lip abraded	Replace the Magazine lip.

## 14 PARTS DIAGRAM

\*The components/accessories for each model may have kind of differences depending on the actual goods. Images are only for reference.

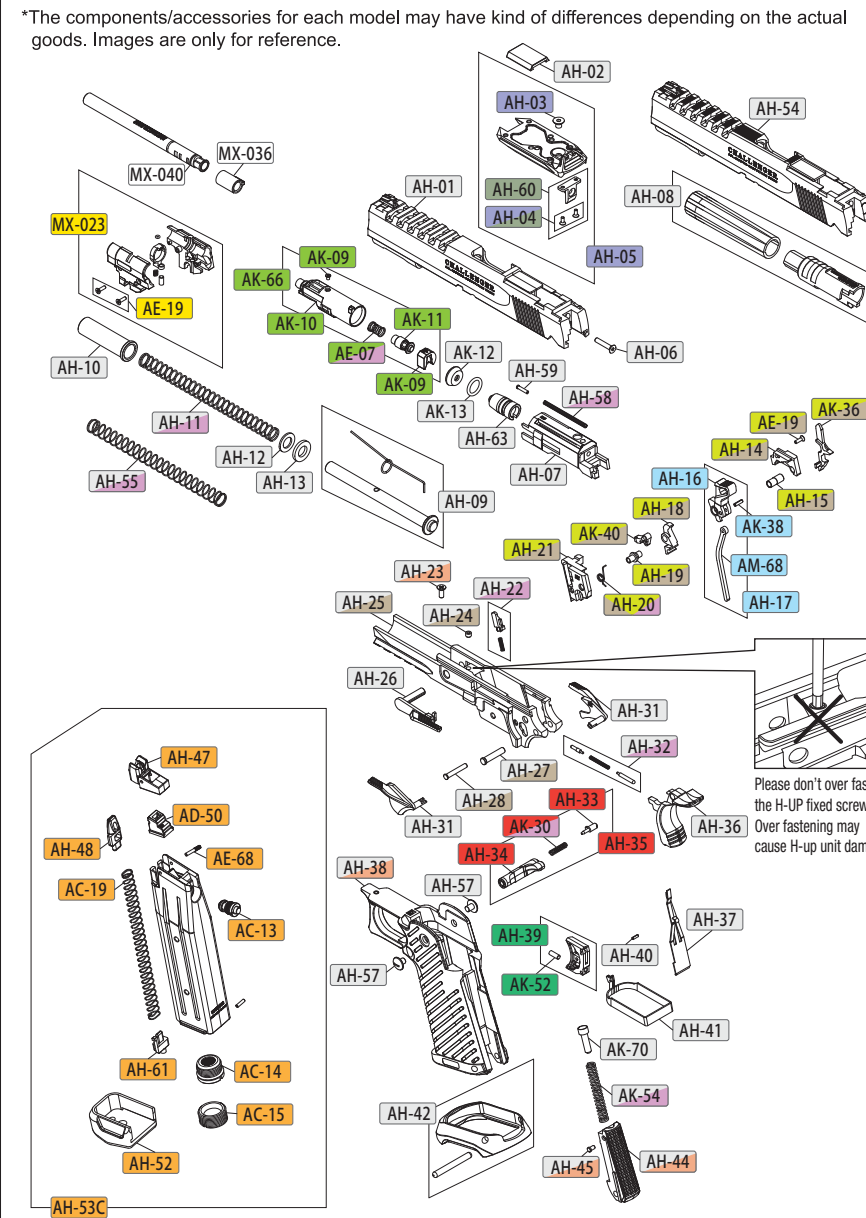

## 15 PARTS DESCRIPTION

ITEM#	DESCRIPTION	Q'TY	ITEM#	DESCRIPTION	Q'TY
AH-01	Hi-Capa Slide with Front Sight	1	AH-56	Hi-Capa Spring Pack	1
AH-02	Hi-Capa Slide Cover	1	AH-57	Hi-Capa Grip Screw	2
AH-03	Hi-Capa Rear Sight Screw	1	AH-58	Hi-Capa Cylinder Housing Spring	1
AH-04	Red Dot Hammer Protection Pad Screw	2	AH-59	Hi-Capa Cylinder Housing Spring Pin	1
AH-05	Hi-Capa RMR & DOC Mount	1	AH-60	Mount Hammer Protection Pad incl. Screw	1
AH-06	Hi-Capa RMR & DOC Mount Screw	1	AH-61	Hi-Capa CO2 Magazine Plate Stop	1
AH-07	Hi-Capa Cylinder Housing	1	AH-63	Hi-Capa Cylinder Cover Housing	1
AH-08	5.1" Hi-Capa Outer Barrel	1	AC-13	CO2 Valve	1
AH-09	5.1" Hi-Capa Recoil Spring Guide Rod with Reverse Plug Retention Clip	1	AC-14	CO2 Cylinder Perforated Seat	1
AH-10	Hi-Capa Recoil Spring Guide	1	AC-15	CO2 Cylinder Housing Spring	1
AH-11	Hi-Capa Recoil Spring	1	AD-50	XPD Magazine Nozzle Seal	1
AH-12	Hi-Capa Shock Buffer Washer	1	AE-07	XAE Valve Spring	1
AH-13	Hi-Capa Shock Buffer Rubber	1	AE-19	XAE H-UP Chamber Screw	3
AH-14	Hi-Capa Hammer Housing-Right	1	AE-68	XAE Magazine Lip Pin	1
AH-15	Hi-Capa Hammer Sleeve	1	AK-09	Vulture Valve Cover with Screw	1
AH-16	Hi-Capa Hammer	1	AK-10	Vulture Cylinder	1
AH-17	Hi-Capa Hammer Combination	1	AK-11	Vulture Valve	1
AH-18	Hi-Capa Sear	1	AK-12	Vulture Valve Plate	1
AH-19	Hi-Capa Sear Sleeve	1	AK-13	Cylinder Cover Housing O-Ring	1
AH-20	Hi-Capa Hammer Knocker Spring	1	AK-30	Vulture Magazine Catch Spring	1
AH-21	Hi-Capa Hammer Housing-Left	1	AK-36	Vulture Hammer Disconnect Pin	1
AH-22	Hi-Capa Hammer Disconnect with Spring	1	AK-38	Hammer Brace Rod Pin	1
AH-23	Hi-Capa Middle Frame Screw	1	AK-40	Vulture Hammer Knocker	1
AH-24	Hi-Capa H-UP Fixed Screw	1	AK-52	Vulture Trigger adjustment Screw	1
AH-25	Hi-Capa Middle Frame	1	AK-54	Hammer Spring	1
AH-26	Hi-Capa Slide Release	1	AK-66	Vulture Cylinder Combination	1
AH-27	Hi-Capa Hammer Pin	1	AK-70	Vulture Hammer Spring Holder	1
AH-28	Hi-Capa Sear Pin	1	AM-68	BM9 Hammer Brace Rod	1
AH-29	Hi-Capa Middle Frame Combination	1	MX-011	Master R-Hop Chamber Rubber FOR GBB	1
AH-30	Hi-Capa Hammer Housing Combination	1	MX-012	Master R-Hop Chamber Rubber	1
AH-31	Hi-Capa Slide Safety	1	MX-015	Master Inner Barrel 113mm	1
AH-32	Slide Release Pin and Spring	1	MX-023	Master Hi-Capa TDC Hop Chamber	1
AH-33	Hi-Capa Magazine Catch Lock	1			
AH-34	Hi-Capa Magazine Catch	1			
AH-35	Hi-Capa Magazine Catch Combination	1			
AH-36	Hi-Capa Grip Safety	1			
AH-37	Hi-Capa Sear Spring	1			
AH-38	Hi-Capa Grip	1			
AH-39	Hi-Capa Trigger	1			
AH-40	Hi-Capa Trigger Bar Pin	1			
AH-41	Hi-Capa Trigger Bar	1			
AH-42	Hi-Capa Magwell & Pin	1			
AH-44	Hi-Capa Hammer Spring Housing	1			
AH-45	Hi-Capa Hammer Spring Lock Pin	1			
AH-46	Hi-Capa Grip Combination	1			
AH-47	Hi-Capa Magazine Lip	1			
AH-48	Hi-Capa Magazine Follower	1			
AH-52	Hi-Capa Magazine Plate	1			
AH-53C	Hi-Capa CO2 Magazine	1			
AH-54	Hi-Capa Plastic Slide with Front Sight	1			
AH-55	Hi-Capa Recoil Spring	1			