

WARNING

- To avoid damaging the product, please release the gas from the magazines or cartridges while not operating.
- Sales and usage are restricted to 18-year-old people or older. Those below 18 years old are not allowed neither to purchase nor to operate alone.
- Never aim or shoot at people or animals. Please beware of childrens' mis-handling.
- Please read and fully understand all details listed in this instruction manual before using this air gun. You can download it from www.icsbb.com if you lose this instruction manual.

6mm BB



1 PART DESCRIPTION

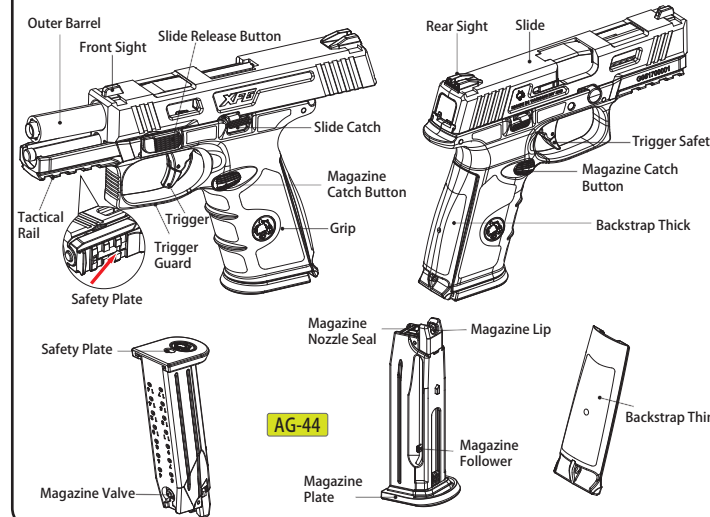

WARNING-ATTENTION



This model is featured with Gas-Blow-Back function. The slide will be pushed back and forth by the gas pressure strongly and rapidly while firing. To prevent injury, please keep your face and finger away from the slide.

The pistol could be damaged when using at temperature of 35°C (95°F) or above.

2 SAFETY DEVICE

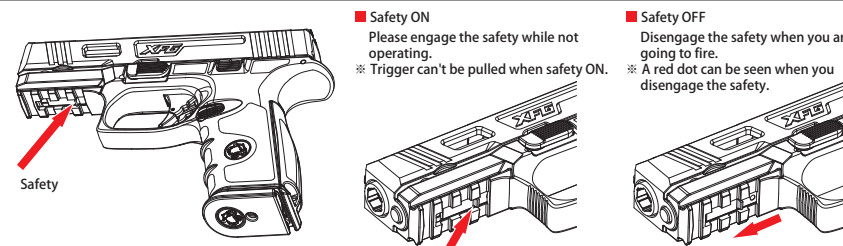

3 LOADING MAGAZINE

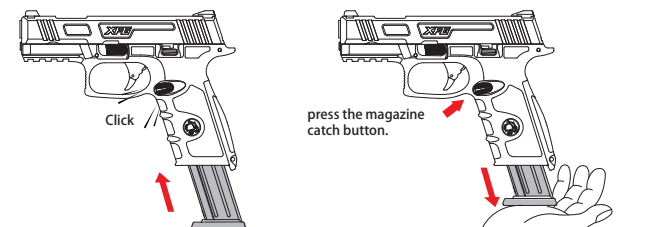

WARNING-ATTENTION

To prevent misfiring, keep your finger off the trigger and out of the trigger guard while loading the magazine.
For safety reason, please remove the magazine while not operating.

4 CHARGING GAS

For the optimum product performance, please charge your magazine with 10-12kg airsoft use green gas. If you use green gas with non-recommended number of kg, it may cause damage or malfunction to the product.

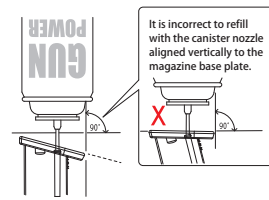

Please turn the magazine up side down to keep the injection hole side up, fill the gas only when the canister is verticalized to the injection hole.
The gas will not be filled into the magazine or will leak out if the canister is not verticalized to the injection hole.

WARNING-ATTENTION

Please avoid to touch the injection hole. It might cause frostbites or low temperature burns if the skin is adhered by the gas.
To preserve the magazine
Magazines are very delicate parts. Dropping them may cause damage or abnormality.
Please avoid foreign matter remains on the magazine lip and injection hole on the magazine, which may cause abnormality.
If refilling is necessary, please avoid to proceed when the magazine is loaded. Please unload the magazine before proceeding.
Please do not place the magazines in wet or watery places, which may cause abnormality.

Precautions while filling:
If you fill the magazine with a non-vertical way from up towards down, and caused the magazine is not completely filled, please deflate the gas completely, and refill the gas one more time as instructed.
Fill the gas until the gas starts to leak out. When the gas is fully filled, gas inside the gas canister and magazine are balance without refilling anymore. It is the normal condition that the gas starts to leak out because it is not able to keep filling. Please stop filling immediately.
Please use your magazine under normal temperature!
If operating in environment of 20°C or below, the gas pressure will drop and might cause abnormal functions. (The magazine will work normally again when temperature returns to normal temperature.)
If operating in environment of 35°C or above, the gas pressure will be too high and might cause abnormal functions. (The magazine will work normally again when temperature returns to normal temperature.)
If you fill the magazine with gas and fire dozens of shots even under normal temperature, the gas pressure will also drop and cause the gas temperature to drop. Preparing several spare magazines for exchange is recommended.

5 LOADING BBs

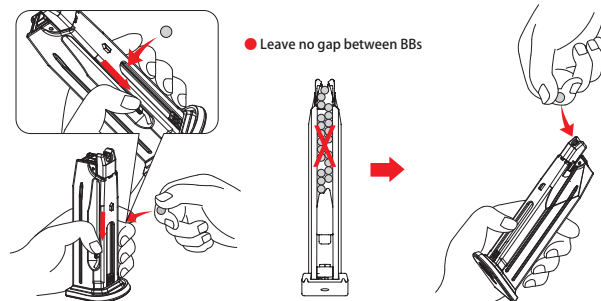

WARNING-ATTENTION

Do not release the magazine follower abruptly while pressing the follower. Releasing the follower carelessly may damage the magazine lip.

Pull the magazine follower down to the end, insert BBs into the BB slot. (Maximum 19 rounds)
You may insert the last BB through the magazine lip.
Do not attempt to insert more than 19 BBs.

6 Loading

- Insert the magazine.
- Pull the slide to the end and hold (the hammer will be pressed down).
- Release the slide (the slide is held at the back at the moment).
- Press the slide catch downward, the slide will be pushed forward (a BB pellet will be loaded into the barrel).
- Pull the trigger to fire.

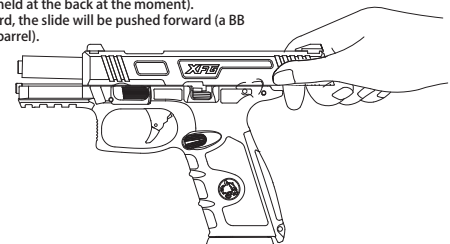

WARNING-ATTENTION

Keep your face and fingers away from the slide while the slide is operating.
When the pistol is unloaded, the slide can be pushed forward when you pull and release it from the end.
When the pistol is loaded, loading repeatedly will makes the BBs load into the barrel repeatedly, which will lead to malfunction while firing and cause danger while firing.
When the hammer is pressed down, pulling the trigger will fire the bb. Please take extra notice.

7 SHOOTING

- Switch the safety to FIRE.
- Load the pistol according to step 6.
- Pull the trigger to fire (a BB pellet will be fired and the slide will be pushed backward).

The slide will be blown back when firing.

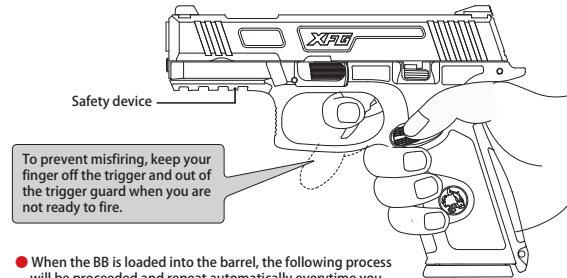

To prevent misfiring, keep your finger off the trigger and out of the trigger guard when you are not ready to fire.

When the BB is loaded into the barrel, the following process will be proceeded and repeat automatically everytime you pull the trigger:
BB fired → Slide movement (blowed backward) → Load the next BB (slide re-positioned)

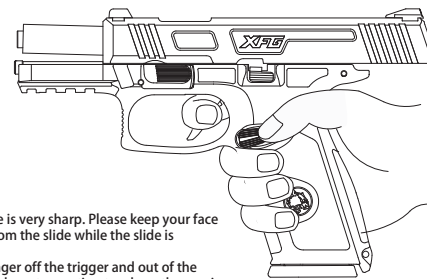

ATTENTION
The rails on the slide is very sharp. Please keep your face and fingers away from the slide while the slide is operating.
Please keep your finger off the trigger and out of the trigger guard, and take extra caution to where the gun is aiming while proceeding non-firing operations.

WARNING-ATTENTION

Power Depression
When the temperature inside the magazine is too low, the gas power will be depressed.
The movement of the slide will be delayed.
The slide catch will not bounced.
The shooting range will not be far.



Shooting posture
Please do not operate the pistol up side down for optium performance.

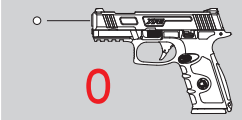

8 STORAGE

- Press the magazine catch button to release the magazine.
- Make sure the inner barrel is clear. If not, pull the slide backward, and turn the pistol up side down to remove (push the BB pellet out from the barrel by the clearing rod is also recommended).
- Press the slide catch lever to release the slide.
- Pull the trigger and fire several times towards safety directions, and make sure no BBs are left inside the barrel.

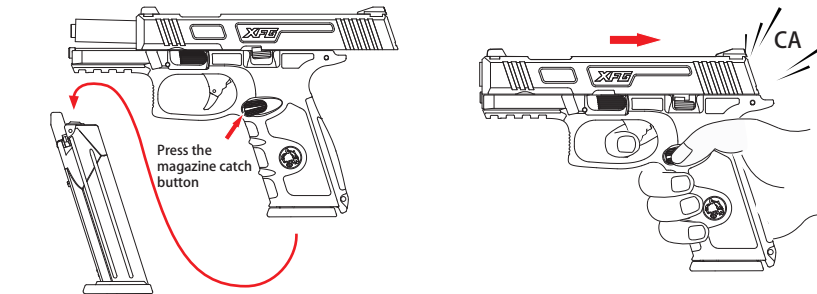

9 DISASSEMBLY (Do it when necessary)

Only disassemble your airsoft when adjusting the H-UP and proceeding to maintenance.

- Press the magazine catch to unload the magazine.
- Pull and hold the slide to the end.

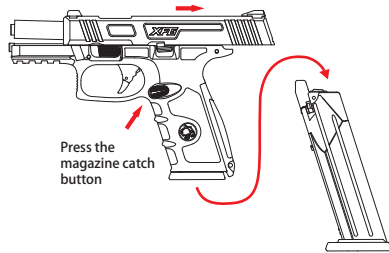

Press the magazine catch button

- Push the slide catch upward to hold the slide at the rear.
- Press the slide release downward, hold your slide with your hand then press the slide catch.

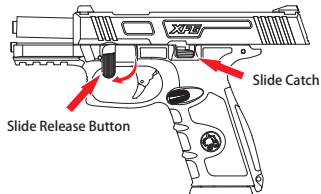

Slide Release Button

Slide Catch

- Push the slide forward to remove.

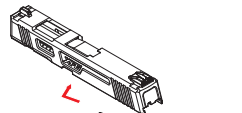

ATTENTION
Please keep your finger off the trigger and out of the trigger guard, and mind where the gun is aiming while proceeding non-firing operations.

- Push the recoil spring guide forward to detach from the frame, then remove it upward.
- Slightly push the outer barrel assembly forward, and then remove it upward.

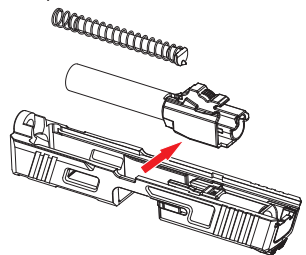

10 H-UP ADJUSTMENT

- Please disassemble and remove the slide as step 9 instructed.
- Slightly rotate the dial to adjust the H-UP.

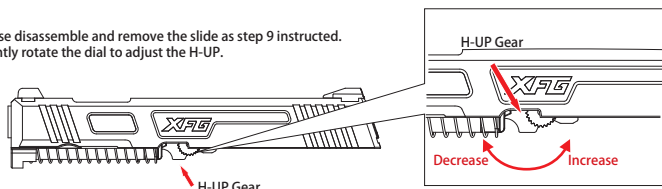

H-UP Gear

Decrease Increase

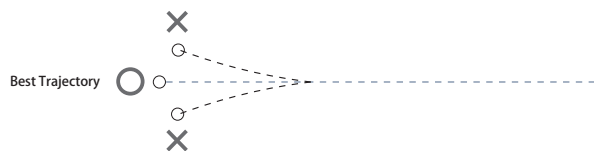

Best Trajectory

H-up Adjustment: Make sure the trajectory of the BB pellets to be straight. When the BB pellet flies up: Rotate the dial clockwise to lower the trajectory. When the BB pellet falls down: Rotate the dial counterclockwise to raise the trajectory.

11 ASSEMBLY

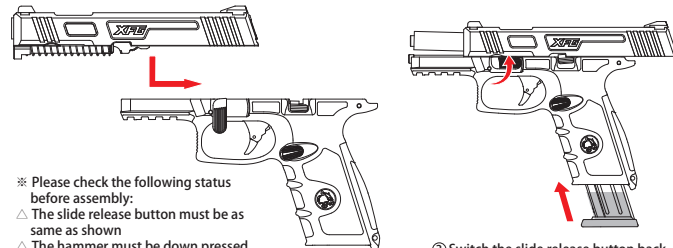

WARNING-ATTENTION

ICS will not be responsible for any mis-assembly, missing parts, and any problems caused by abnormality such as malfunctions, accidents, injuries, caused by malfunction, and all the maintaining expenses will be borne by the customer themselves.

- ※ Please check the following status before assembly:
- △ The slide release button must be as same as shown
 - △ The hammer must be down pressed.
- Insert the slide back into the receiver through the rail from the front.
 - Push and hold the slide to the end.

- Switch the slide release button back to its horizontal position, then release the slide.
- Load an empty magazine.

12 BASIC TROUBLESHOOTING GUIDE

SYMPTOMS	POSSIBLE CAUSES	SOLUTIONS
No Response	The safety is ON. (No firing)	Switch the safety to "OFF" (refer to step 2)
	Magazine overpressured.	Press the valve gently to release gas and to adjust pressure. Be careful when gas discharges from the nozzle seal.
	Insufficient gas inside the magazine.	Charge gas into magazine (refer to step 4)
The slide blows back but no BB is fired.	BB can't be loaded into the barrel.	Load the first BB into the barrel (refer to step 6)
	BB jams inside the magazine.	Push out the BB by using the clearing rod, or pull the slide backward, and turn the pistol up side down to remove.
Will not complete cycle	Magazine is too cold.	Use the magazine after it returned to normal temperature (refer to step 4).
	Temperature is too low.	
	Magazine is too cold.	
Slide jammed	No gas in the magazine.	Charge gas into magazine (refer to step 4)
	Lubricant or silicon oil is not enough.	Apply lubricant to the moving parts.
	BBs or foreign matters jammed inside the slide or frame.	Remove the BBs or foreign matters.
Gas comes out from the barrel	Slide Catch is not switched back to locking position.	Switch the slide release button to horizontal locking position (refer to step 11)
	Temperature is too low.	Use the magazine after it returned to normal temperature (refer to step 4).
BBs fly up	Magazine is too cold.	
	H-UP is over adjusted.	Adjust the H-UP gear clockwise .
Shooting range is too short	H-UP isn't adjusted enough.	Adjust the H-UP gear counterclockwise .
	Foreign matters or oil in the inner barrel.	Clean the inner barrel and H-UP bucking.
BBs roll out of barrel	H-UP isn't adjusted enough.	Adjust the H-UP gear counterclockwise.
	H-UP is over adjusted.	Adjust the H-UP gear clockwise.
Jammed	Bad BBs, oversize BBs	0.2g to 0.25g 6mm caliber BBs are recommended for optimum performance.
	Foreign matters or oil in the inner barrel.	Clean the inner barrel.

13 PARTS DIAGRAM

*The components/accessories for each model may have kind of differences depending on the actual goods. Images are only for reference.

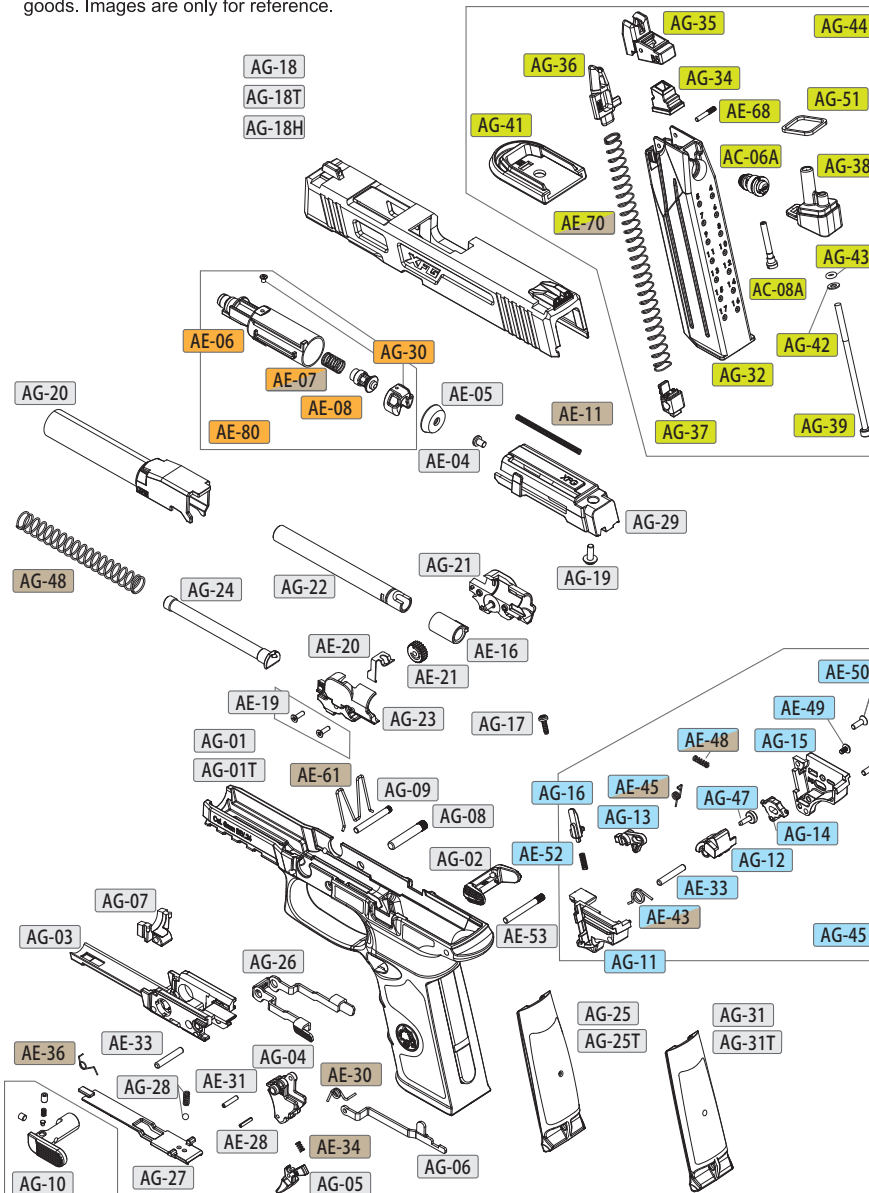

14 PARTS DESCRIPTION

ITEM#	DESCRIPTION	Q'TY	ITEM#	DESCRIPTION	Q'TY
AG-01	XFG Frame-BK	1	AE-76	XFG Magazine Base O-Ring	1
AG-01T	XFG Frame-TAN	1	AG-41	XFG Magazine Plate	1
AG-02	XFG Magazine Catch	1	AG-42	Washer	1
AG-03	XFG Trigger Housing	1	AG-43	Screw O-Ring	1
AG-04	XFG Trigger	1	AG-44	XFG Magazine	1
AG-05	XFG Trigger Safety	1	AG-45	XFG Hammer Parts	1
AG-06	XFG Trigger Bar	1	AG-46	XFG Spring Parts	1
AG-07	XFG Slide Positioning Block	1	AG-51	XFG Magazine O-ring	1
AG-08	Trigger Housing Pin-Rear	1	AE-04	M1 Screw	1
AG-09	Trigger Housing Pin-Front	1	AE-05	XAE Valve Plate	1
AG-10	Slide Disassemble Lever	1	AE-06	XAE Cylinder	1
AG-11	Hammer Housing-Left	1	AE-07	XAE Valve Spring	1
AG-12	XFG Hammer	1	AE-08	XAE Valve	1
AG-13	XFG Knocker	1	AE-11	XAE Cylinder Housing Spring	1
AG-14	XFG Sear with Spacer	1	AE-16	XAE H-UP Bucking	1
AG-15	Hammer Housing-Right	1	AE-19	XAE H-UP Chamber Screw	2
AG-16	XFG Knocker Lock	1	AE-20	XAE H-UP Plate	1
AG-17	Housing Attaching Screw	1	AE-21	H-UP Dial	1
AG-18	XFG Slide-BK	1	AG-48	XFG Recoil Spring	1
AG-18T	XFG Slide-TAN	1	AE-28	Trigger Safety Pin	1
AG-18H	XFG Slide-Hairline	1	AE-30	XAE Trigger Bar Spring	1
AG-19	Cylinder Housing Screw	1	AE-31	Trigger Bar Spring Pin	1
AG-20	XFG Outer Barrel	1	AE-33	Slide Catch Lever Plate Pin	1
AG-21	XFG H-UP Chamber-Right	1	AE-34	XAE Trigger Spring	1
AG-22	XFG Inner Barrel	1	AE-36	XAE Slide Locking Plate Pin	1
AG-23	XFG H-UP Chamber-Left	1	AE-43	XAE Hammer Spring	1
AG-24	XFG Recoil Spring Guide	1	AE-44	XAE Hammer Guide Wheel	1
AG-25	XFG Backstrap Thick-BK	1	AE-45	XAE Hammer Bar Spring	1
AG-25T	XFG Backstrap Thick-TAN	1	AE-48	XAE Hammer Disconnect Spring	1
AG-26	XFG Slide Catch	1	AE-49	Round Head Hammer Housing Screw	1
AG-27	XFG Safety Plate	1	AE-50	Flat Head Hammer Housing Screw	2
AG-28	Bearing Ball and Spring	1	AE-52	XAE Hammer Disconnect Pin Spring	1
AG-29	XFG Cylinder Housing	1	AE-53	XAE Hammer Housing Pin	1
AG-30	Valve Cover and Screw	1	AE-61	XAE Magazine Catch Spring	1
AG-31	XFG Backstrap Slim-BK	1	AE-68	XAE Magazine Lip Pin	1
AG-31T	XFG Backstrap Slim-TAN	1	AE-70	XAE Magazine Follower Spring	1
AG-32	XFG Magazine Case	1	AE-80	XAE Cylinder Parts	1
AG-34	XFG Magazine Nozzle Seal	1	AC-06A	REVO Energy Valve	1
AG-35	XFG Magazine Lip	1	AC-08A	REVO Energy Nozzle	1
AG-36	XFG Magazine Follower	1			
AG-37	XFG Magazine Plate Stopper	1			
AG-38	XFG Magazine Base	1			
AG-39	XFG Magazine Base Screw	1			